



MOBILE AND STATIC SMOKE CURTAIN
BLOCKCURTAIN
DA150-DH60



The smoke curtain **BLOCKCURTAIN DA150 - DH60** has been tested for a durability of up to 60 minutes at 1000 °C and up to 150 minutes at 600 °C, have the function of smoke and harmful gases control as integration of the smoke extraction system, conveying smoke to evacuation systems (e.g. smoke evacuators) BLOCKCURTAIN DA150 - DH60 is a mobile and partially flexible fire curtain, normally wrapped inside an head box made in galvanized steel (the head box dimensions vary in according to the curtain measurements and the installation conditions) The fabric is made with glass fiber, resistant to the high temperatures, on both side is covered with poliurethanic material, not flammable on both sides and has a weight of 460 gr/mq. The fabric is available in grey, (white and black on request).

A counterweight supplied with a steel profile of 50mm coated RAL 9010 (standard), helps the fabric to be held in tension on the whole curtain's width once open. The weight is proportional to the curtain's dimension.



1. Galvanized steel head box different dimensions according to the model type
» see characteristics pag.13
2. Casing and winding shaft's supports brackets
3. Winding shaft
4. Gravity Fail System drive
» see characteristics pag.16
5. Lateral side guide with holding tube (only on request)
» see characteristics pag. 15
6. Vertical holding system, holding tube
» see characteristics pag. 15
7. Fabric
8. Counterweight and bottom bar element
» see characteristics pag. 15



Lateral side guides are on request and made of galvanized steel 2,00 mm thick with a dimension of 120 x 70 mm. Through an internal tube, the fabric is hold along the whole height that also helps the fabric sliding, that results more linear and tensioned.

BLOCKCURTAIN DA150 - DH60 is normally supplied with an internal tubular drive 24V, inserted on the winding shaft and guarantee linearity and a compact aesthetic and functionality.

Once the curtain receive the fire alarm or in case of power failure the curtain thanks to the Gravity fail safe system descend with a controlled speed.

The control panel, always supplied, can control multiple modules and has an integrated Ups battery in case of main power failure.

Frontwall and upper fixation on mansory with screws and steel anchors

On request: Lateral side guides, coating with RAL colors of side guides, and of a different color than RAL 9010 of the counterweight bottom bar element, white or black fabric.

BLOCKCURTAIN DA150 - DH60 is CE MARKED in according to **EN 12101-1:2005/A1:2006**

CSH SYSTEM

Simple system (a single module) for small dimensions and easy installation mode, W. max. 5500 mm.
Everything is delivered assembled and ready for installation

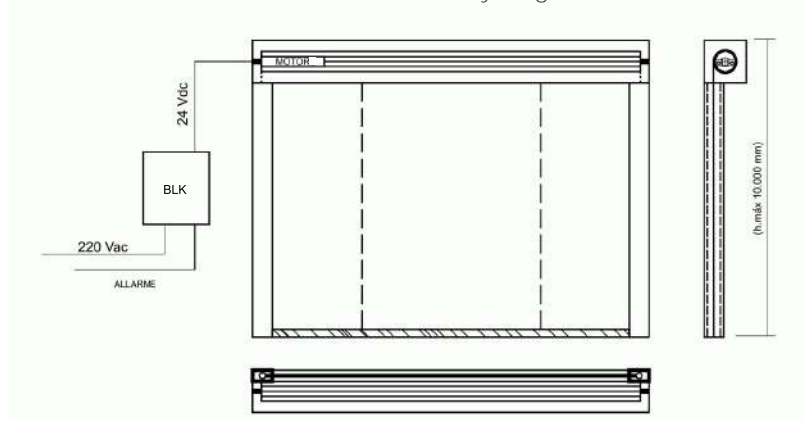

CDH SYSTEM

Combined system consisting of modules with W. max. 5,500 mm. each. The coverage of the dimensions required in the project can be obtained through the modulation and overlapping of the rollers

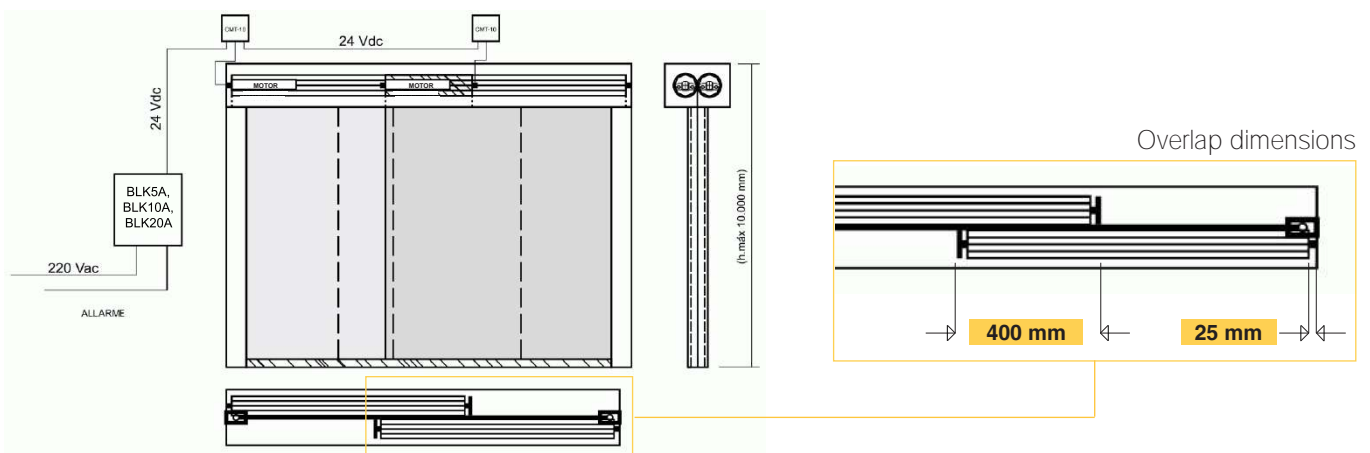

CDV SYSTEM

Combined system composed of modules of W. max. 5.500 mm (each module), ideal for front installations. The coverage of the dimensions required in the project can be obtained through the modulation and overlapping of the rollers.

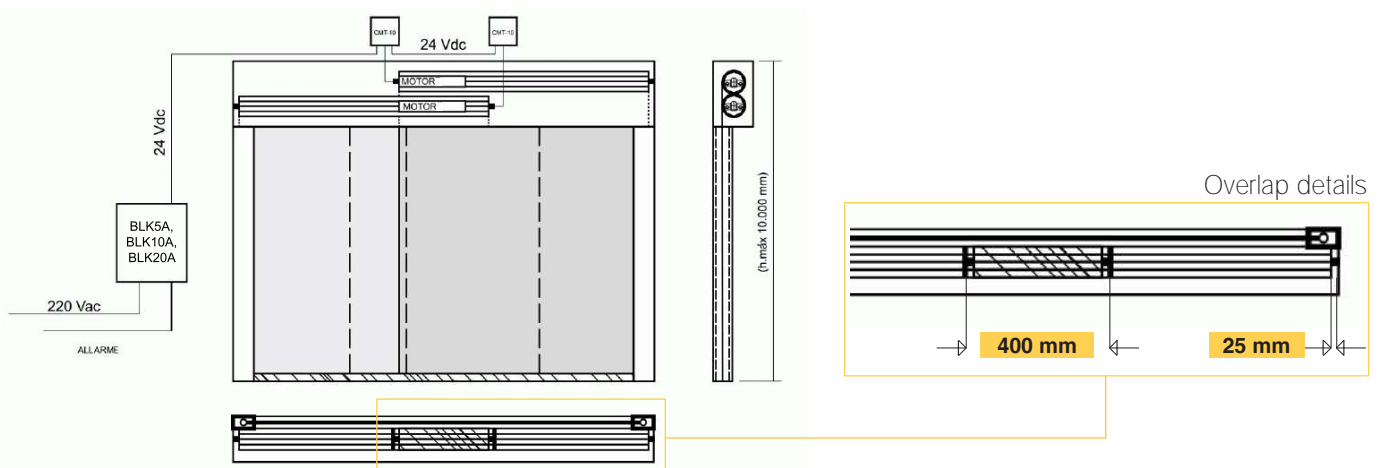

HEAD BOX TECHNICAL CHARACTERISTICS

The **BLOCKCURTAIN DA150-DH60** smoke curtains are essential elements to be included in the smoke evacuation system. They are used both in industrial and commercial contexts, thanks to the reduced dimensions of the head box; the supply of side guides is on request.

Thanks to the composition in overlapping modules (400 mm minimum overlap) they can cover unlimited widths. (see features on page 12)

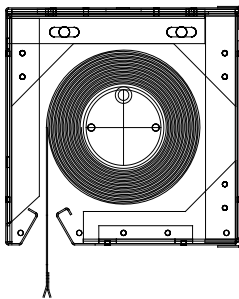

MODEL CSH

Head box made of galvanized bent steel sheet, for single modul curtain, maximum width 5500 mm.

| Casing model | Maximum module dimensions W. x H. (mm) | | Casing maximum dimensions D. x H. (mm) |
|--------------|--|------|--|
| Series S22 | 5500 | 8000 | 220x220 |

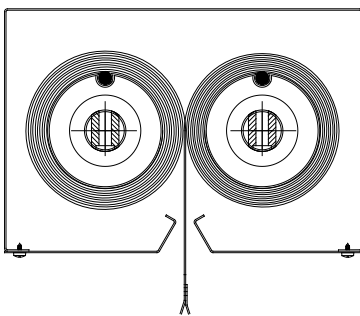

MODEL CDH

Head box made of galvanized bent steel sheet, for curtains made of multiple modules

| Casing model | Maximum module dimensions W. x H. (mm) | Casing maximum dimensions D. x H. (mm) |
|--------------|--|--|
| Series H | fino a 5500 | 250x170 |
| Series HL | oltre 5500 | 270x200 |

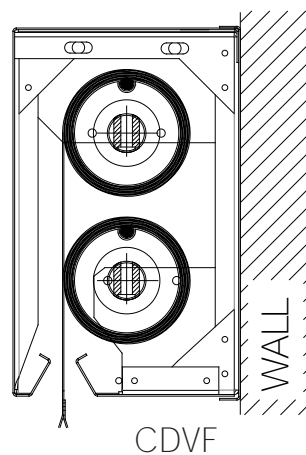
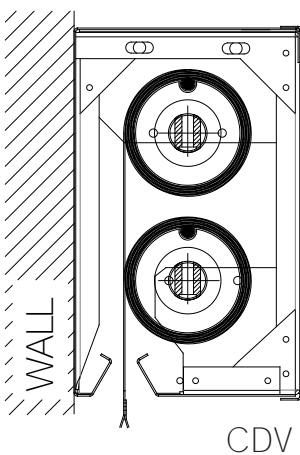

MODEL CDV / CDVF

Head box made of galvanized bent steel sheet, for curtains made of multiple modules

| Casing model CDV | Module dimensions (mm) | Casing maximum dimensions D. x H. (mm) |
|------------------|------------------------|--|
| Serie V | H. up to 5500 | 170 x 280 |
| Serie VL | H. ≥ 5500 | 200 x 360 |

| Casing model CDVF | Module dimensions (mm) | Casing maximum dimensions D. x H. (mm) |
|-------------------|------------------------|--|
| Serie VF | H. up to 5500 | 170 x 280 |
| Serie HL | H. ≥ 5500 | 200 x 360 |

HEAD BOX INSTALLATION TYPES

HEAD BOX MODEL CSH

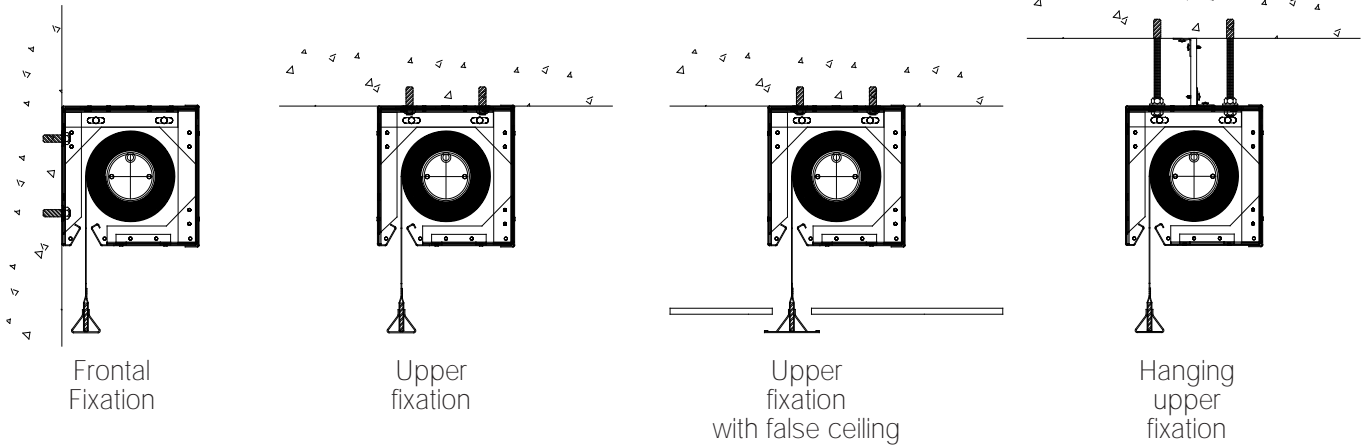

HEAD BOX MODEL CDH

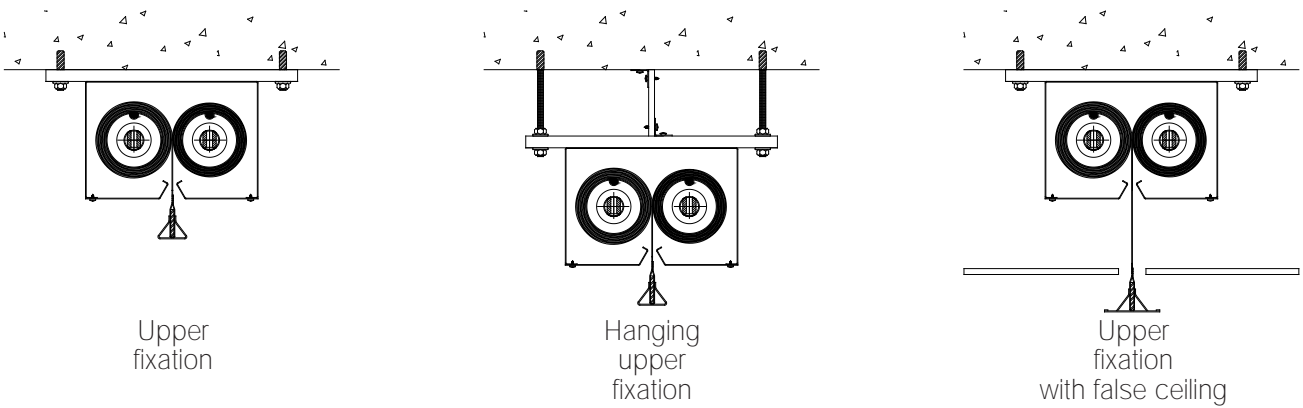

HEAD BOX MODEL CDV

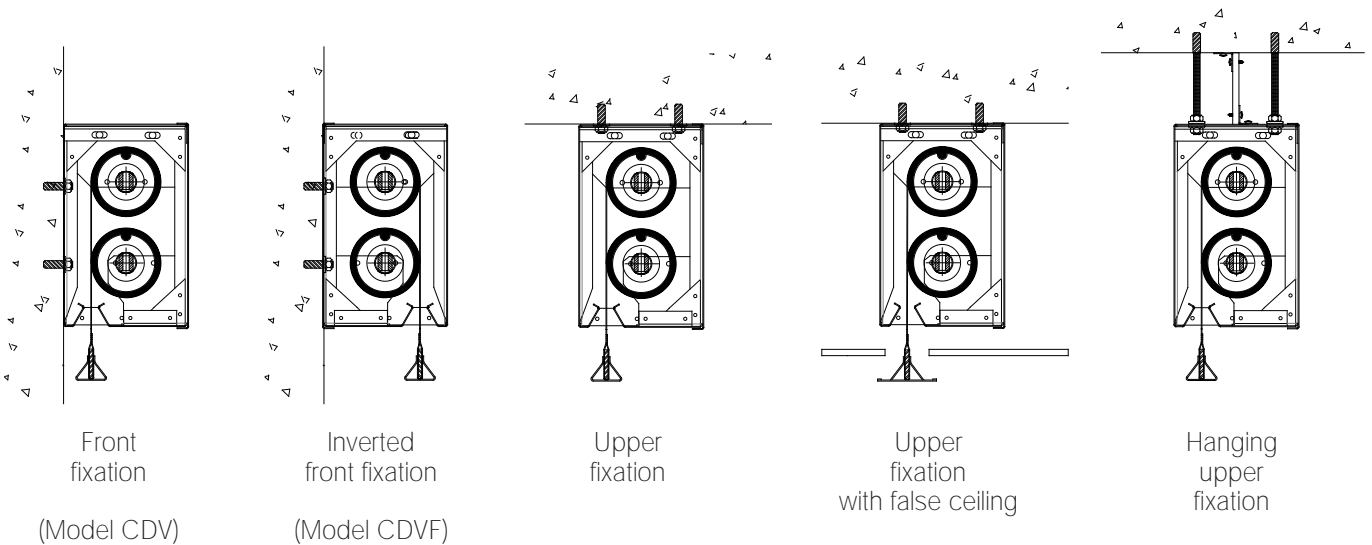

Important: all the supports must guarantee a even or superior fire resistance. Screws, rivets and all the attachments must have a diameter at least of 8mm.

BOTTOM BAR ELEMENT

The tension of the fabric is guaranteed by the terminal with a counterweight element, placed at the end of the curtain, which facilitates the vertical descent. Made of extruded aluminum, standard RAL 9010 coated. The internal counterweight can vary depending on the size of the curtain and the weight needed to keep the fabric taut during the descent.

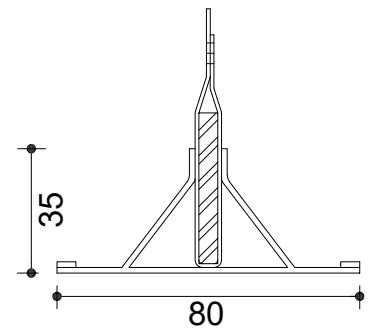
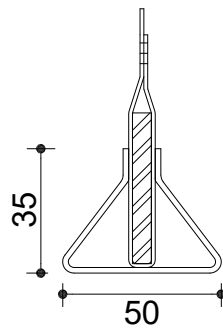
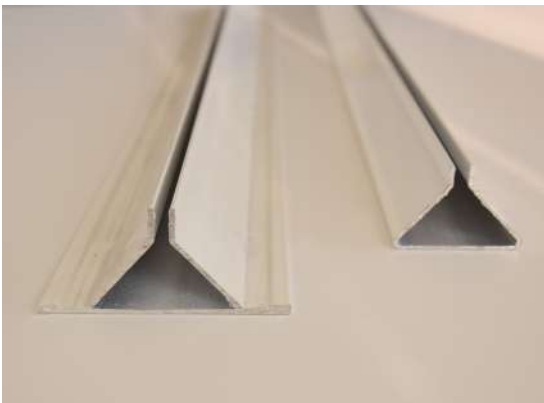

(see application on the previous page)

LATERAL SIDE GUIDES CHARACTERISTICS

The lateral sliding guides (1) with a vertical tube inside which hold the fabric (2), give greater tension to the awning and facilitate sliding during descent.

The guides are made of galvanized steel and can be supplied painted in RAL colors on request.

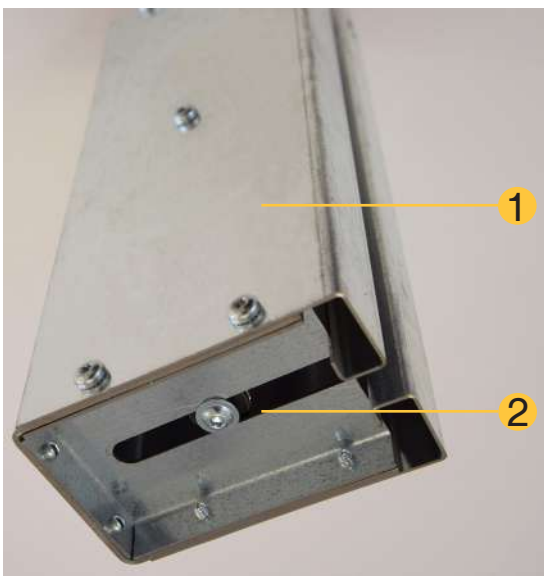

bottom view

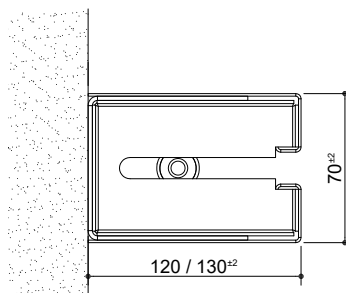

Lateral fixation

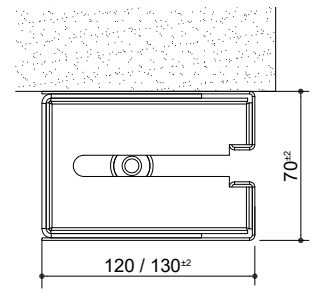

Front wall fixation

| Guide type | Curtains dimensions max H. (mm) | Guide dimensions max W. x D (mm) |
|------------|---------------------------------|----------------------------------|
| SG120 | up to 4500 | 120x70 |
| SG130 | over 4500 | 130x70 |

Important lateral side guides are optionals and supplied only on request



| MCT 2A MOTOR | General Characteristic |
|----------------------|------------------------|
| Voltage | 24 V |
| Speed | 25 rpm |
| Nominal torque | 5.10 N/m |
| Maximum current | 3A |
| Power | 20 W |
| Degree of protection | IP 67 |



| MCT 5A MOTOR | General Characteristic |
|----------------------|------------------------|
| Voltage | 24 V |
| Speed | 14 / 8 rpm |
| Nominal torque | 30/60 N/m |
| Maximum current | 6,3 A |
| Power | 150 W |
| Degree of protection | IP 44 |

Both motors are supplied with the adapter for octagonal or round shaft of variable dimensions in according to the model type. The set consists of an electric motor and planetary reducer housed inside a metal housing. The drive is equipped with a system that control the speed descent (Gravity fall safe system), when the fire alarm signal starts or in case of main power failure.

APPLICATION OF THE MOTOR TYPE

| in mm. | Width | | | | | | | | | | |
|--------|---|------|------|------|------|------|------|------|------|------|------|
| | 500 | 1000 | 1500 | 2000 | 2500 | 3000 | 3500 | 4000 | 4500 | 5000 | 5500 |
| Height | <div style="display: flex; justify-content: space-around; align-items: center;"> <div style="text-align: center;">MCT 2 A</div> <div style="text-align: center;">MCT 5 A</div> </div> | | | | | | | | | | |
| 500 | | | | | | | | | | | |
| 1000 | | | | | | | | | | | |
| 1500 | | | | | | | | | | | |
| 2000 | | | | | | | | | | | |
| 2500 | | | | | | | | | | | |
| 3000 | | | | | | | | | | | |
| 3500 | | | | | | | | | | | |
| 4000 | | | | | | | | | | | |
| 4500 | | | | | | | | | | | |
| 5000 | | | | | | | | | | | |
| 5500 | | | | | | | | | | | |
| 6000 | | | | | | | | | | | |
| 6500 | | | | | | | | | | | |
| 7000 | | | | | | | | | | | |
| 7500 | | | | | | | | | | | |
| 8000 | | | | | | | | | | | |

Example of single connection with control panel type BLK

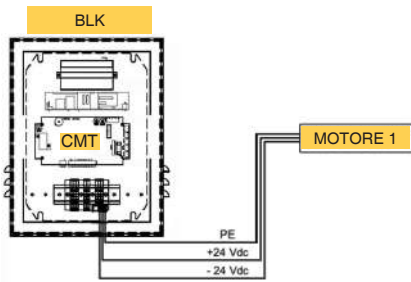

BLK control panels are programmable modules for the control of automatic protection systems; they are used for the activation and management of systems and are responsible for constantly checking the engine's status.

When the control panel receive an alarm or an open contact signal, sends an activation order to the curtains, closing the compartmentalization space.

BLK control panels are individual system with integrated UPS module which guarantee autonomy for 2 hours operation in case of loss of main power supply.

Example of multiple connection with control panel BLK 5A/10A/20A + CMT

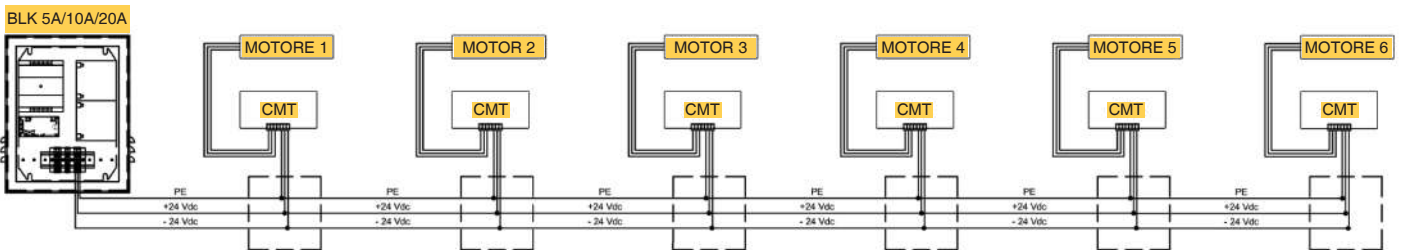

BLK 5A/10A/20A control panels are programmable modules to control the fire and smoke containment systems. **BLOCKCURTAIN DA150-DH60**, are connected in according to the number of motors and control panels as follow: BLK in case of single drive, BLK 5 A, BLK 10 A and BLK 20 A in case of multiple drives or curtains up to 12 units. Through the control unit you can adjust the speed descent and power during installation, so as to ensure the perfect adaptation of the product to the hole to protect.

They are individual systems through an integrated UPS module which guarantees autonomy of 4-6 hours operation in case of loss of main power supply.

Below there is the combinations chart with drives MCT2A and MCT5A.

Control panel activity is ensured with a 24v back up battery that guarantee, in case of general power supply loss, the activity of the electric brake in order to maintain the curtain wrapped.

| Control panel | Configuration | Drives | |
|---------------|---------------|----------|---------|
| | | MCT 2 A | MCT 5 A |
| BLK | A | 1 unit. | - |
| | B | - | 1 unit. |
| BLK 5 A | A | 2 unit. | - |
| | B | - | 1 unit. |
| BLK 10 A | A | 6 unit. | - |
| | B | - | 2 unit. |
| | C | 2 unit. | 1 unit. |
| BLK 20 A | A | 12 unit. | - |
| | B | - | 4 unit. |
| | C | 2 unit. | 3 unit. |
| | D | 4 unit. | 2 unit. |
| | E | 5 unit. | 1 unit. |

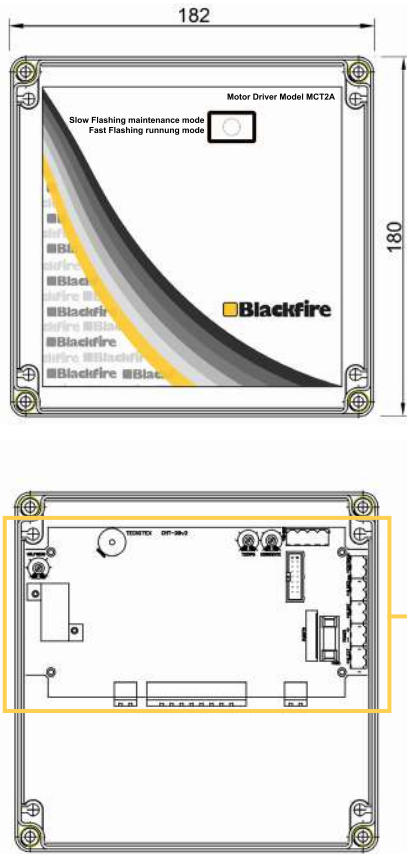

Control panel CMT

The control unit status can be constantly monitored by means of 3 external LEDs associated with the key test, with which the descent can be carried out manually during periodic operation checks.

All the control units are set up for a smoke detection system junction.

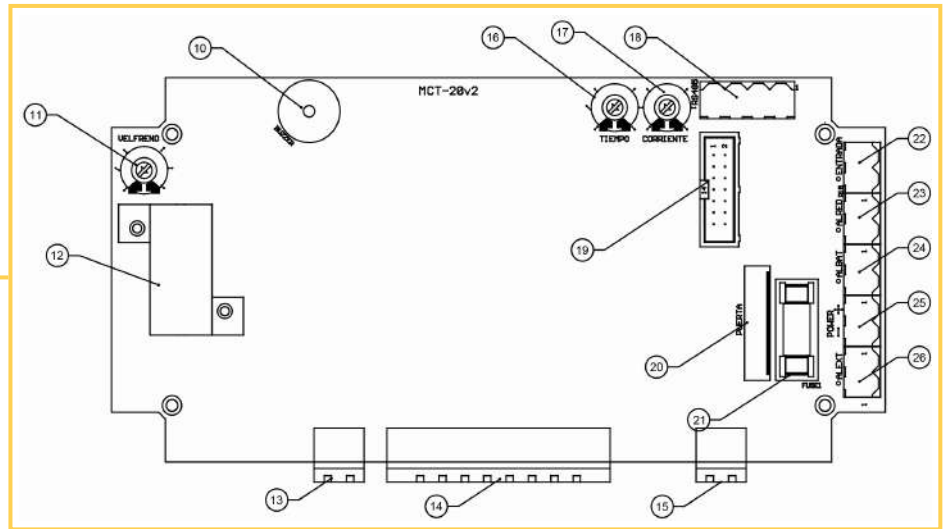

| Rif | ITEM | DETAIL |
|-----|--|---|
| 10 | ACOUSTIC BUZZER | ACOUSTIC BUZZER IN CASE OF ALARM |
| 11 | POTENTIOMETER VELOCITY BRAKE | POTENTIOMETER IN CHARGE OF REGULATING THE SPEED OF DESCENT |
| 12 | BRAKE HEATSINK | ELEMENT HEATSINK FOR THE TEMPERATURE GENERATED IN THE BRAKE SYSTEM |
| 13 | ENABLE TERMINAL (MOTOR MCT2A) | TERMINAL FOR CONNECTION OF MOTOR ENABLE SIGNAL (MOTOR MCT2A) |
| | ELECTRO MECHANICAL BRAKE (MOTOR MCT5A) | TERMINAL FOR CONNECTION ELECTRO MECHANICAL BRAKE (MOTOR MCT5A) |
| 14 | MOTOR TERMINAL | MOTOR TERMINAL |
| 15 | OVERHEATING MOTOR SIGNAL | TERMINAL FOR CONNECTION OF OVERHEATING MOTOR SIGNAL (DEPENDING OF MOTOR MODEL) |
| 16 | POTENTIOMER OPERATING TIME | POTENTIOMETER IN CHARGE OF REGULATING THE OPERATING TIME OF THE SYSTEM |
| 17 | OPERATING POWER POTENTIOMETER | POTENTIOMETER IN CHARGE OF REGULATING THE OPERATING POWER OF THE SYSTEM |
| 18 | RS485 TERMINAL | CONNECTION TERMINAL FOR RS485 COMMUNICATION PROTOCOL |
| 19 | TERMINAL PROGRAMMING | TERMINAL FOR PROGRAMING CMT-20 ELECTRONIC BOARD |
| 20 | LEDS AND KEY TEST TERMINAL | TERMINAL FOR CONNECTING LEDES INDICATORS AND TEST KEY LOCATED IN THE PANEL DOOR |
| 21 | SAFETY FUSE | SAFETY FUSE FOR OVERCURRENT OR SHORT CIRCUIT |
| 22 | GENERAL PURPOSE INPUT | GENERAL INPUT CONTACT FOR GENERAL PURPOSE |
| 23 | 220V ALARM TERMINAL | TERMINAL IN BOARD FOR ALARM MAIN POWER 220 V |
| 24 | BATTERY ALARM TERMINAL | TERMINAL IN BOARD FOR BATTERY ALARM STATUS |
| 25 | 24Vdc INPUT TERMINAL | TERMINAL IN BOARD FOR 24 Vdc INPUT |
| 26 | FIRE ALARM TERMINAL | TERMINAL IN BOARD FOR FIRE ALARM |

GENERAL CHARACTERISTIC OF THE STATIC SYSTEM

BLOCKCURTAIN DA150 - DH60 STATIC is tested to a heat exposure up to 60 minutes at 1000°C and up to 150 minutes to 600°C and has the function of smoke and hot harmful gases control, the curtain works as an integration to the smoke extraction system, channelling the smoke toward the smoke evacuation system (es. smoke vents)

Is a curtain that maintain always the fire position.

The fabric is realized with a fiber glass that withstand high temperatures, covered on both sides with polyurethanic material, the weight is 460gr/mq. The fabric is available in 3 grey (white and black on request).

Is possible to realize large modules adapting the fabric without interfere with structural elements or ventilation pipes and without loosign the smoke compartmentation in open spaces

Fixation on mansory with screws and steel anchors.

BLOCKCURTAIN DA150 - DH60 FISSA is **CE MARKED** in according to regulation:

EN 12101-1:2005/A1:2006



BLOCKCURTAIN DA150-DH60 STATIC

is specially designed to be installed in large spaces, warehouses or logistics centers.

It is a light, effective and inexpensive system for areas where the fixed position of the barrier does not interfere with operations or activities in the premises of its location.

1. Galvanized steel bead
2. Fabric
3. Counterweight rod

Shapes available:

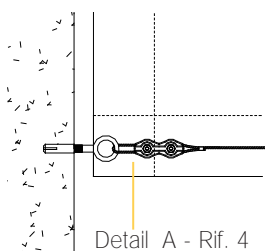
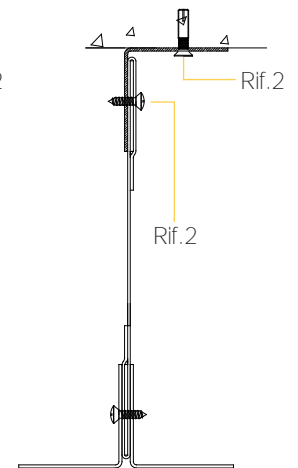
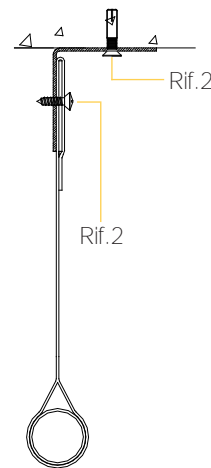
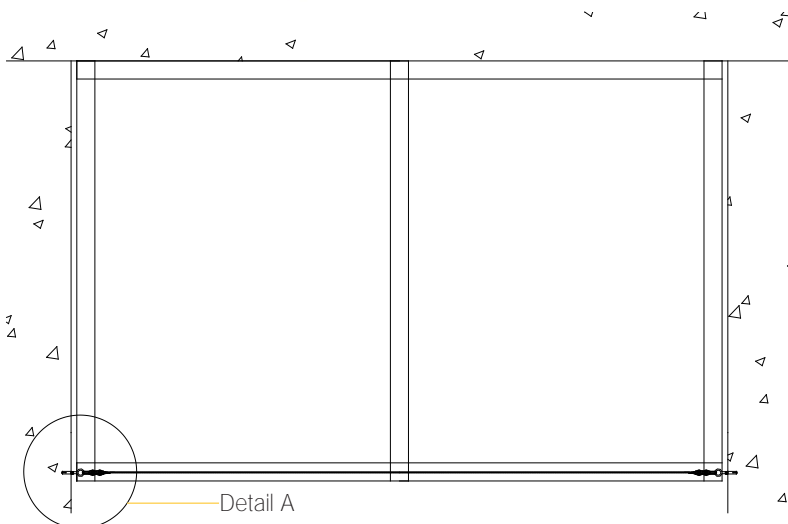
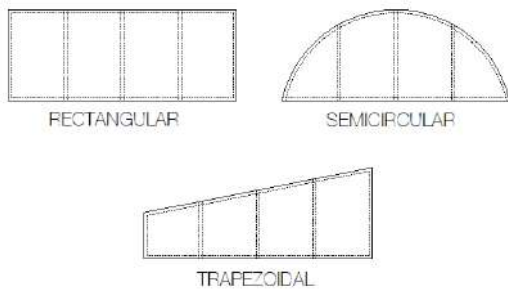

| Rif. | Detailed |
|------|---|
| 1 | Top fixing using a 40x40x1.2 mm galvanized angular profile fixed to the lower face of the concrete beam, by means of a metallic fastener and screw. |
| 2 | Fixation procedure of the smoke barrier TECNITEX SSB DH-60/DA-150 to a angular profile previously fixed, using rivets or steel drill screws 4.2 mm each 800mm |
| 3 | Counterweight made by steel rod, steel round pipe (maximum weight 5Kg/lm). |
| 4 | Counterweight made by tensioned steel wire with side eyebolts. |
| 5 | Counterweight using a double 40x40x1.2 mm galvanized angular profile fixed using steel screws or rivets 4.2 mm thicknees each 800 mm. |