

*Fire Shutter*  
***BLOCKSHUTTER EW120***

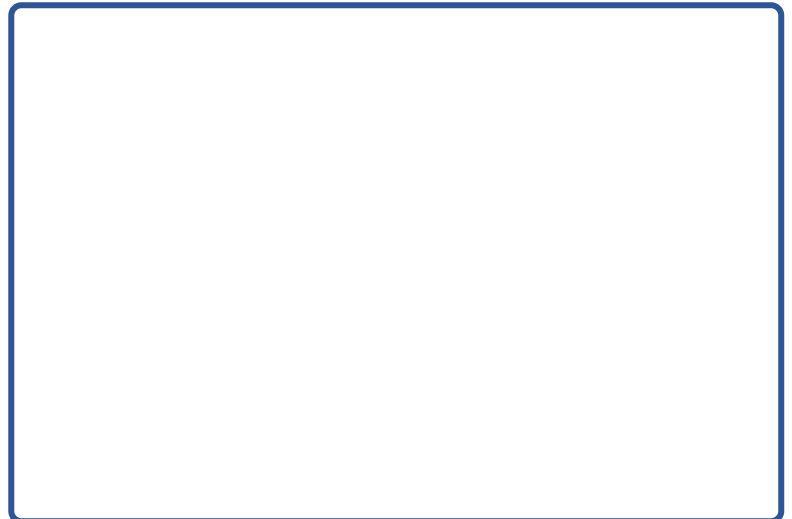

**INDEX**

1. PACKAGING AND TRANSPORT	P.04
2. DISPOSAL	P.05
3. PRELIMINARY CHECKS	P.05
4. FIRE SHUTTER BLACKFIRE EI TECHNICAL DRAWING	P.06
5. ROLLING SHUTTER LIST OF COMPONENTS	P.07
6. ASSEMBLY SEQUENCE	P.08
7. ELECTRICAL CONNECTIONS	P.13
8. ADJUSTMENT OF LIMIT SWITCHES	P.13
9. USE	P.13
10. CONTROLS	P.13
11. CLEANING AND LUBRICATION	P.13
12. MAINTENANCE	P.14
13. SPARE PARTS	P.15
14. TROUBLESHOOTING	P.15
15. GUARANTEE	P.16
16. RISK ANALYSIS	P.16
17. MAINTENANCE INTERVENTIONS REGISTER	P.18

**IMPORTANT**

**All drawings in this manual are purely indicative and non-binding. The Customer is required to verify (see page 8) the suitability of the support (wall) for the installation of the shutter and the tightness of the anchor points (fixings are not included).**

At the end of assembly, the **Installer** must deliver all the CE documentation to the **Customer / User**, together with the *declaration of correct installation*, logging on the test report the delivery of the documentation and the training for the safe use of the roller shutter.

*Dear Customer,*

Thank you for choosing our Fire Shutter with **EW120 resistance performance**.

It has been designed and constructed in accordance with:

- ❖ CPR 305/2011 (Construction Products Regulation);
- ❖ Machinery Directive 2006/42/EC
- ❖ Electromagnetic Compatibility Directive 2014/30/EU
- ❖ Low Voltage Directive 2014/35/EU
- ❖ Norm RED (Radio Equipment Directive) 2014/53/UE
- ❖ Directive 2011/65/EU RoHS II - Restrictions on the use of hazardous substances

following the indications of the rules:

- ❖ UNI EN 13241:2016 Industrial, commercial, garage doors and gates – Product standard, performance characteristics;
- ❖ UNI EN 12604:2017 Industrial, commercial, garage doors and gates – Mechanical aspects – Requirements and test methods;
- ❖ UNI EN 12453:2017 Industrial, commercial, garage doors and gates – Safety in use of motorized doors – Requirements and test methods;
- ❖ UNI EN 16034:2014 Pedestrian doors, industrial, commercial, garage doors and opening windows - Product standard, performance characteristics - Fire resistance and / or smoke control characteristics;

and tested according to the standards:

- ❖ UNI EN 1634-1:2018 Fire resistance and smoke dispersion control tests for doors and closing systems, opening windows and their construction accessories - Part 1: Fire resistance tests for doors and closing systems and opening windows;
- ❖ UNI EN 1363-2:2001 Fire resistance tests - Alternative and additional procedures;
- ❖ UNI EN 15269-10:2011 Extended application of the results of fire resistance tests and/or smoke dispersion control for doors, locking systems and opening windows and their construction components - Part 10: Fire resistance of steel roller shutters;

In addition, EC documents are issued consisting of:

- ❖ Installation, Use, Maintenance and Safety Manual;
- ❖ Motor Manual;
- ❖ Manual of the Control Panel (if any);
- ❖ Safety device manuals with related declarations of conformity issued by manufacturers;
- ❖ DOP (Declaration of Performance);
- ❖ CE label (applied to the product).

All the document must be kept by the *Customer / User* and shown to the maintenance / repair personnel in order to log any intervention after installation.

In order to maintain the performance declared in PDO, it is **MANDATORY** to carry out the scheduled and conservative maintenance, provided in this manual, under penalty of forfeiture of any form of warranty.

This Manual is aimed at *trained and qualified installers and users*, and is intended to provide indications for correct Assembly, Safe Use and Maintenance and highlight the risks and dangers during Assembly, Use, Maintenance.

**BLACKFIRE® is a trademark of CONEGLIANO GROUP SRL**

**IMPORTANT**

This Manual must be read in its entirety before installation, use and maintenance of the Fire Shutter and must be kept near it in a transparent rain folder.

This Manual and its contents are the exclusive property of the Manufacturer. Any unauthorized reproduction will be prosecuted in accordance with the Law. The Manufacturer reserves the right to make changes to the product and/or technical documentation for the purpose of its improvement without prior notice.

Assembly and maintenance personnel must be properly trained in workplace safety. To ensure the integrity of the components of the shutter it is necessary to comply with the following indications:

1. To avoid corrosion problems before installation, the material must be parked in covered and dry places; moreover, sufficient ventilation of the site where the shutter is installed must be ensured.
2. Do not use solvents or other concentrated chemical compounds that could damage painted, plasticized or galvanized finishes when cleaning the elements or components of the shutter.
3. Do not use high pressure washers for cleaning.
4. The compartment where the shutter must be installed must guarantee an adequate outflow of rainwater so that there is no infiltration or stagnation of water near it.
5. All the parts that make up the shutter must be assembled according to the indications of this manual and the specifications produced to order (drawings) or manuals of the manufacturers of the control and safety components.

The Manufacturer will decline all responsibility for malfunction of the shutter if non-compliance of assembly, use and maintenance is ascertained, with respect to the requirements of this manual. All the elements of the shutter have been chosen according to precise design guidelines to ensure perfect operation. The Manufacturer will decline any responsibility for malfunction of the shutter in the event of ascertained assembly of components of Third Parties.

**DANGER**

The shutter is equipped with active and passive safety devices. In case of their intervention, do not attempt unlocking maneuvers but request the intervention of specialized personnel recognized by the Manufacturer. Irregular maneuvers can cause damage to property or people. In case of maintenance of the motor make sure that the shutter stations in the closed position.

**1. PACKAGING AND TRANSPORT**

In loading, unloading and delivery operations, be sure to pair packages bearing the same Order / Item number and Model. The EW fire shutter is packed in a wooden cage and consists of Guides (right + left), horizontal beam, Push shaft; Support brackets (motor and parachute); EW (supplied already wrapped on the winding shaft) complete with bearing, shaft pinion, and fall arrest device; Engine, Sprocket; Accessory Box with Transmission Chain, Siren / Flashing Light with Base, Small Parts; Technical and CE documentation (**attention wall fixings are not provided**).

In case of shipments of several shutters, the pieces can be grouped. The handling of packages must be carried out with the utmost care using suitable forklifts or pallet trucks. Storage must be carried out in a covered place. At the time of unloading, the customer must verify the presence and integrity of all the pieces indicated in the transport Document and within 24 hours can report any shortages or non-conformities. Complaints must be received by e-mail or fax and be supported by photos documenting the problem encountered. Only in this case the Manufacturer will be able to take charge of the resolution of the problem detected, if attributable to him.

## 2. DISPOSAL

The disposal of the mechanical parts of the shutter must be carried out through authorized scrapping companies. Polystyrene, plastic strapping, cardboard constituting packaging, wood constituting stacking frames can be assimilated to municipal solid waste. The slats, the rubber gaskets, the motorization and the electrical components are special waste to be disposed of through authorized companies.

## 3. PRELIMINARY CHECKS

Before proceeding with the assembly operations, carry out the following preliminary checks:  
Carry out the survey of the masonry compartment reporting the values on the following diagram;

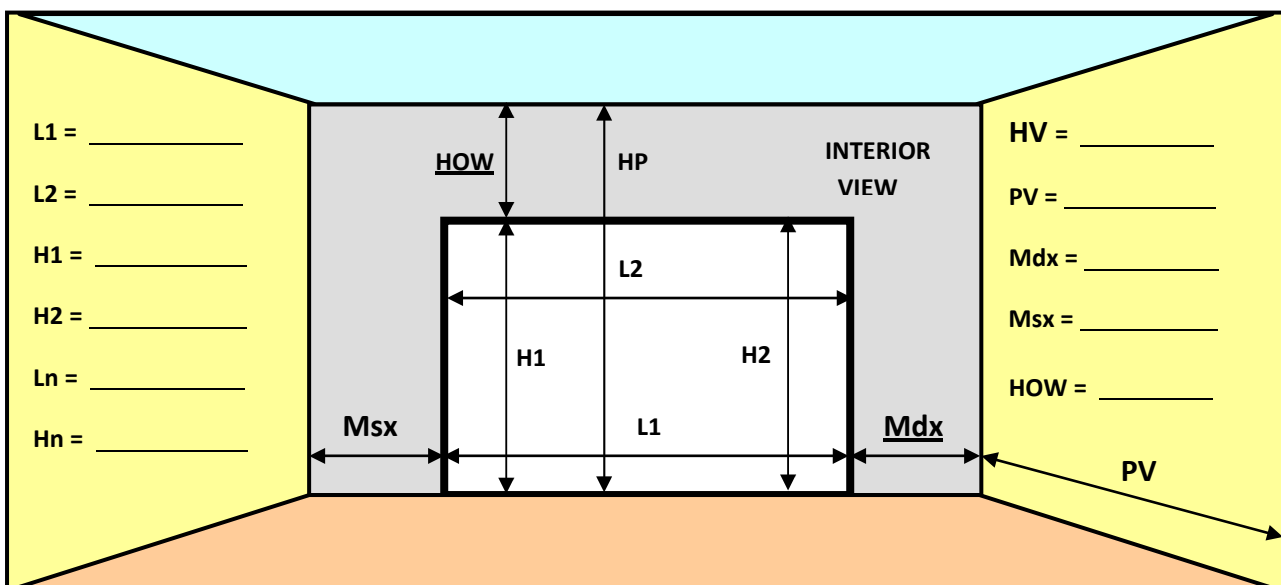

- Define the values of Ln (width) and Hn (nominal height) determining them on the basis of the maximum values detected (L1 and L2) (H1 and H2) net of any false squares. The values of L and H indicated on the label on the packages must be equal to Ln and Hn or deviate in excess of a maximum of 10 mm.
- Check the consistency of the walls on which the fixings will be made in order to identify the correct ones to be used.
- Check that there are no impediments (electrical ducts, water pipes, beams, etc.) in the installation and sliding area of the shutter.
- Check the level of the floor and the level of the side tangent.

## 4. BLACKFIRE FIRE ROLLING SHUTTER EW120 TECHNICAL DRAWING

The EW fire rolling shutter is built for mounting beyond the opening, with clear opening  $L \leq 12$  mt  $H \leq 9$  mt (The weight of the slats is about  $30\text{kg/m}^2$ ). Caution, for  $L > 8$  mt the depth of the guides will increase by 20mm with consequent dimensional increase.

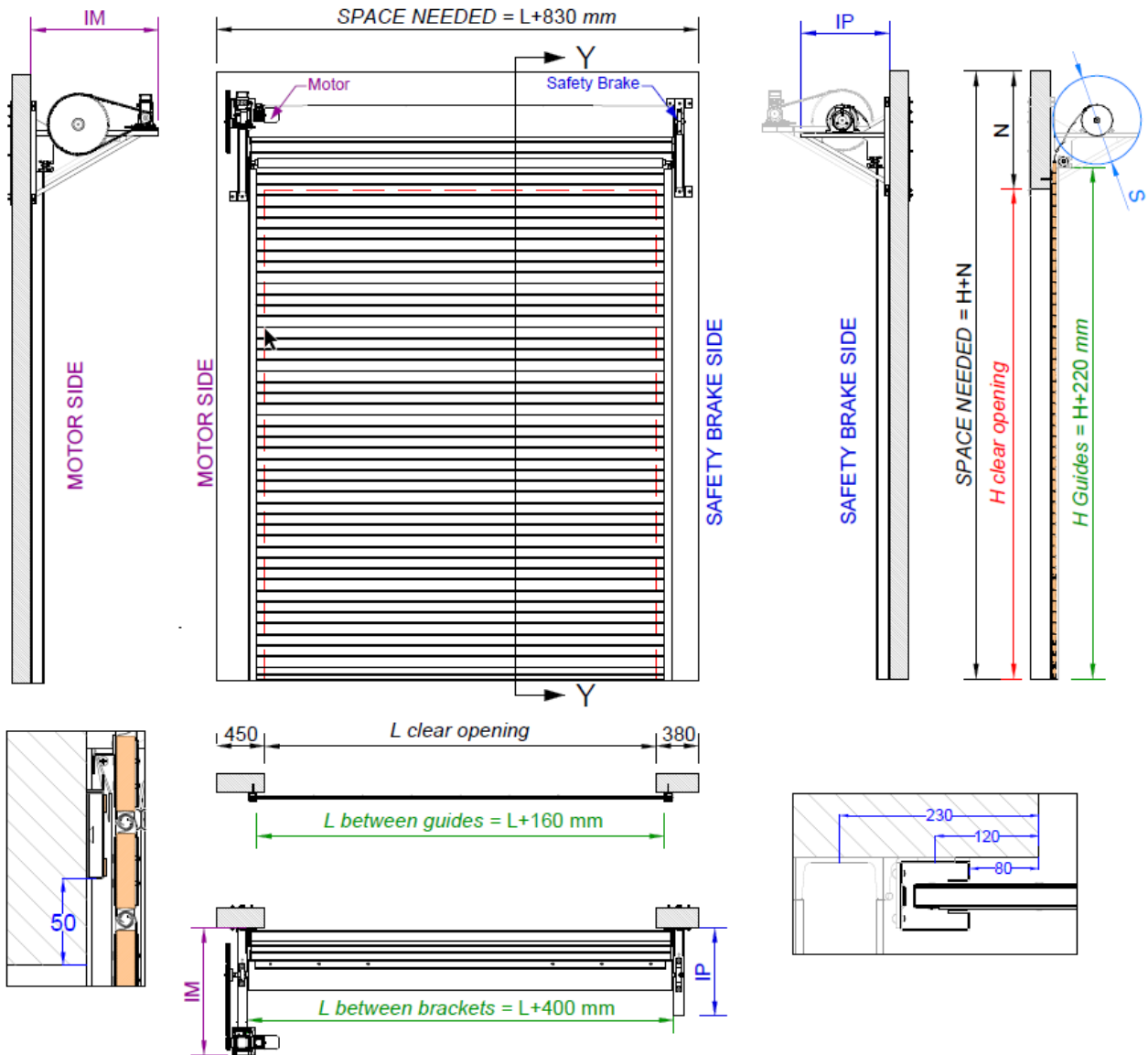

The motor in the drawing is an example. The motor position is at the customer choice.



**5. FIRE ROLLING SHUTTER LIST OF COMPONENTS**

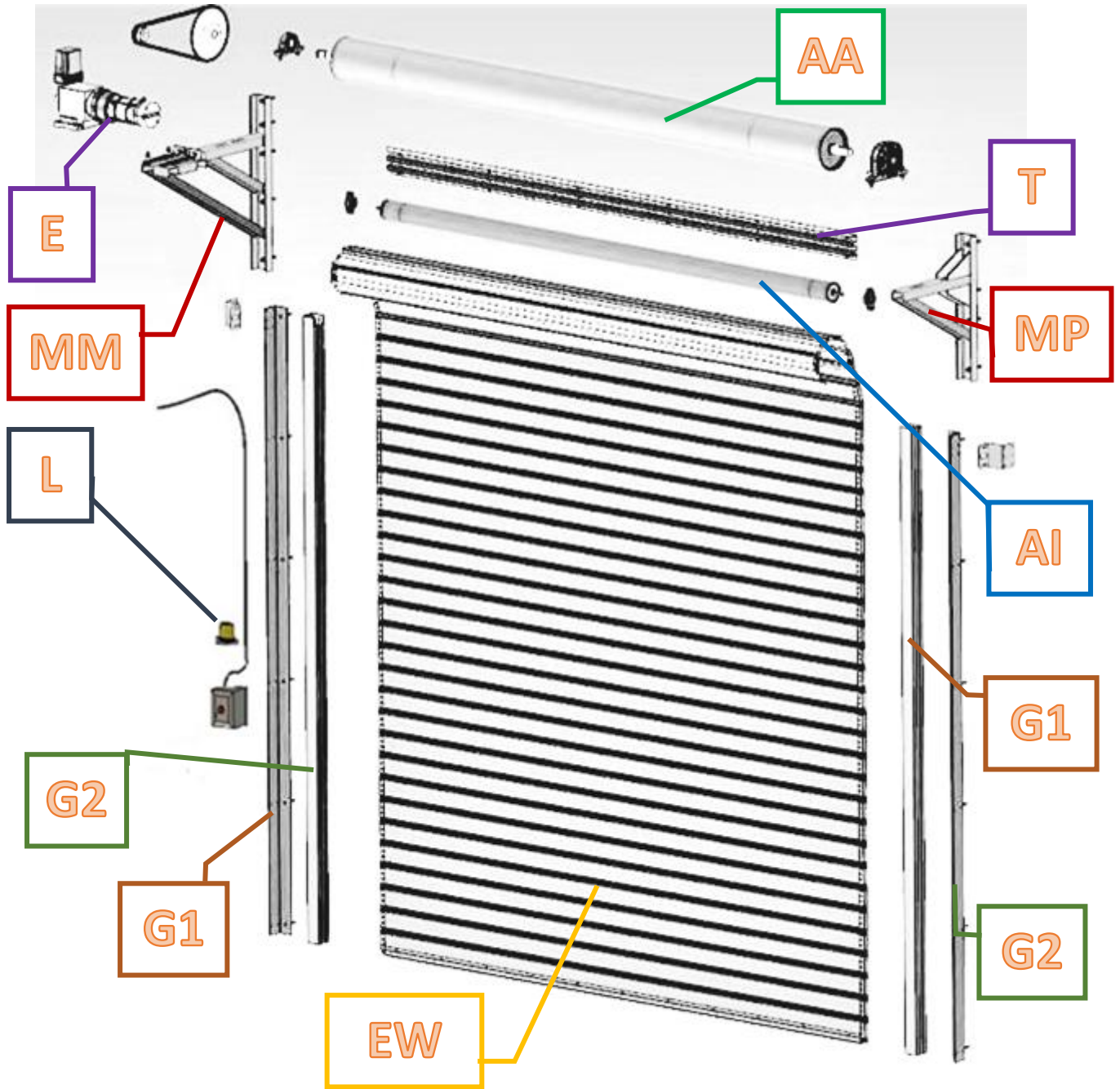

G1/G2) Guides (in two parts);  
 T) Beam Plate;  
 MP) Safety Brake bracket;  
 MM) Motor bracket;  
 AA) Roll shaft;

EW) EW slats (supplied already rolled on AA);  
 AI) Push shaft;  
 E) Motor  
 L) Flashing light with acoustic alarm

**BLACKFIRE® is a trademark of CONEGLIANO GROUP SRL**

Via Campolongo N.1/E • Zona Industriale Ramera • 31010 • Mareno di Piave • Treviso • Italy  
 Tel: +39 0438.4985 • Web site: [www.blackfireitaly.it](http://www.blackfireitaly.it) • Email: [info@blackfireitaly.it](mailto:info@blackfireitaly.it)  
 P.I. - C.F. - REG. IMP.: 00532460268 • Number R.E.A. TV-125284



## 6. ASSEMBLY SEQUENCE

### **IMPORTANT**

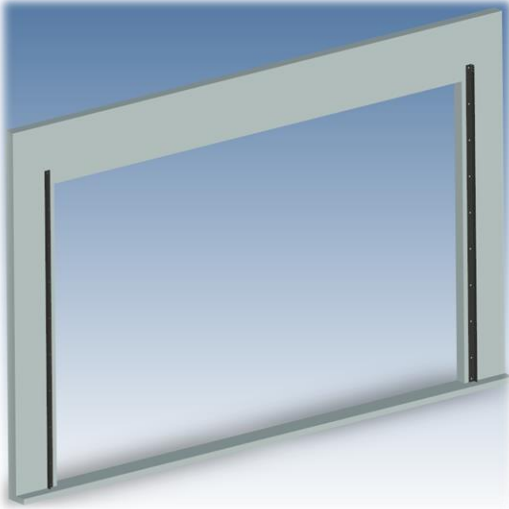
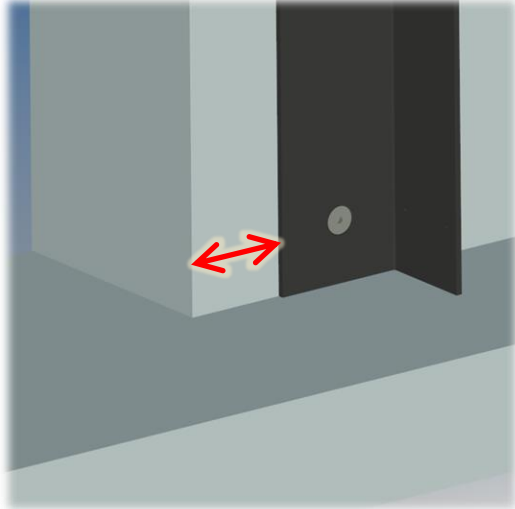
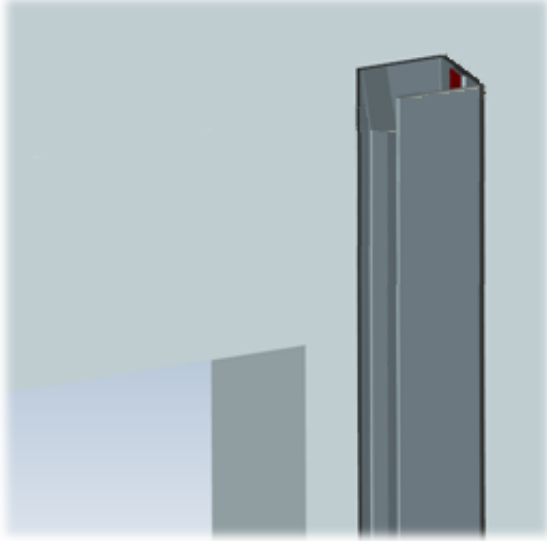
The EW Fire Rolling Shutter is designed to be installed **beyond the opening** on a *rigid support with 200mm thickness and 450kg/m<sup>3</sup> density* (characteristics of fire resistance only), the Client must verify that the structural characteristics of the support are suitable for the installation of the shutter. It is possible to fix it on a protected structural steel support it is sized according to EN15269-10: 2011. Fasteners are not included. **Use only fasteners that are suitable for the mechanical strength and fire resistance provided and that fit the mounting surface.** *Use the "Installation Instructions" attached to the order for correct installation.*

<p>Step.01: Assembly of <b>G1</b> guides</p>	<p>Position from the clear passage: <b>80mm</b></p>
	
<p>Step.02: Assembly of <b>G2</b> guides</p>	
<p>Fix the guide <b>G2</b> to the guide <b>G1</b> by inserting self-drilling screws (supplied) in the series of holes.</p>	

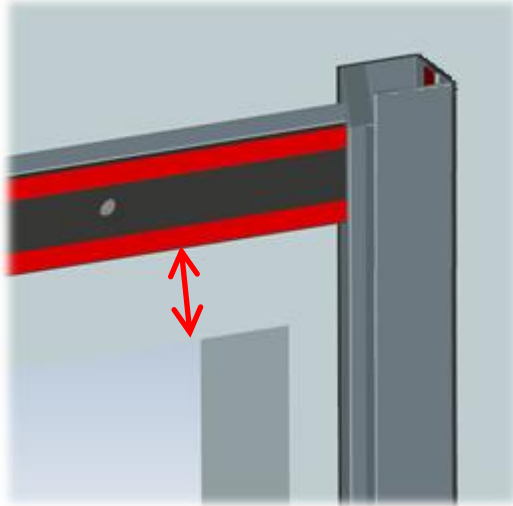

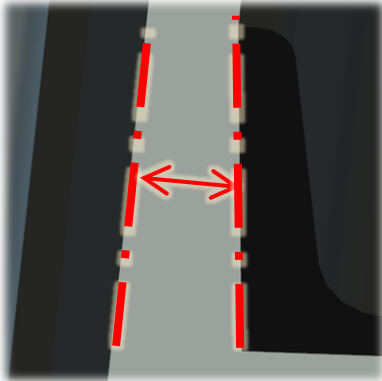
Step.03: Assembly of Beam Plate <b>T</b>	Beam Plate from the clear passage: <b>50mm</b>
	
Step.04: Mounting Brackets <b>MM-MP</b>	Position from the guides <b>15mm</b>
	 <p>Fixing with M12 threaded bar and back plate. Fixing height of the brackets: <b>variable</b>, see installation scheme attached to the order.</p>

Step.05: Winding shaft assembly (rolled up elements) **EW+AA**

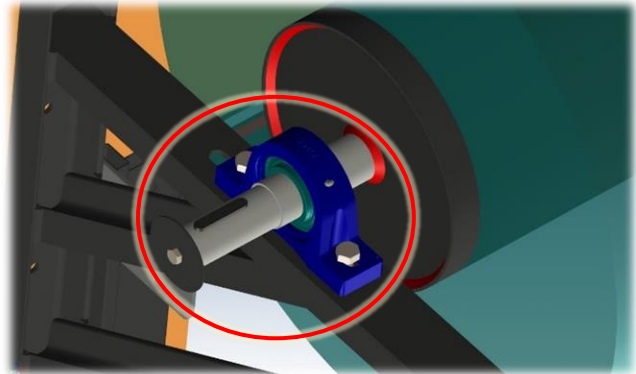
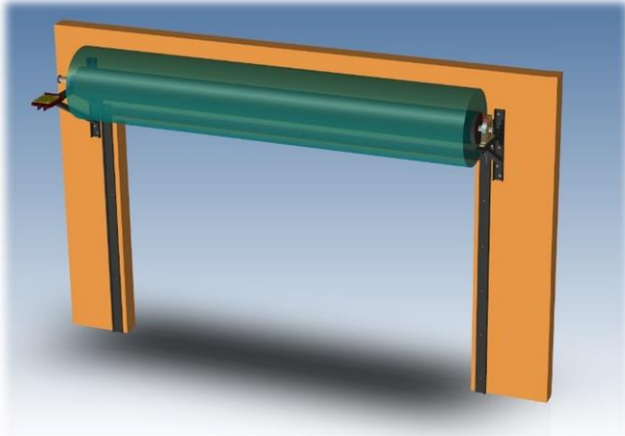

Fixing of the bearing on the motor bracket

The shaft with the rolled up elements is contained in a dedicated packaging. Remove the lid and all sides of the packaging by freeing the axes, check that the grub screws on the sprocket and parachute are tightly screwed so that they cannot move. With suitable means, lift the bottom of the packaging together with the shaft, remove the sides of the bottom part and place it between the brackets. Adjust the distance between the wall and the winding axis as per the fixing diagram attached. In the end, remove the remaining packaging. The parachute must then be connected to the control unit (if fitted). **Caution: Do not remove the strapping that keeps the shutter rolled up (Step.9).**

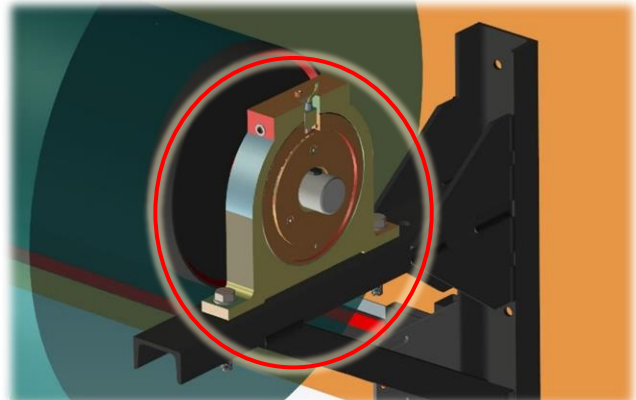

Parachute fixing on parachute shelf

Step.06: Push shaft mounting **AI**

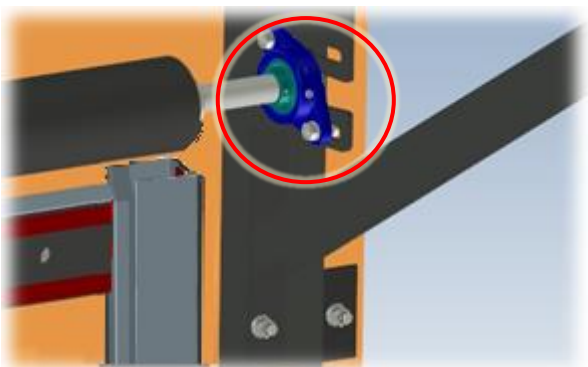
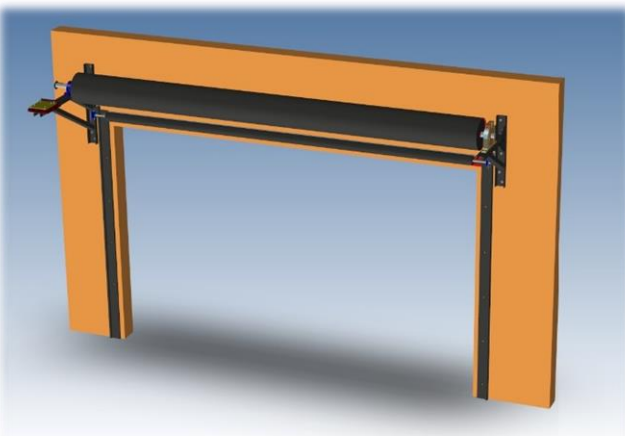

Attach the push shaft to the bracket using the supplied flanged bearings. The distance must be adjusted according to the slats.

Step.07: Mounting motor *E*

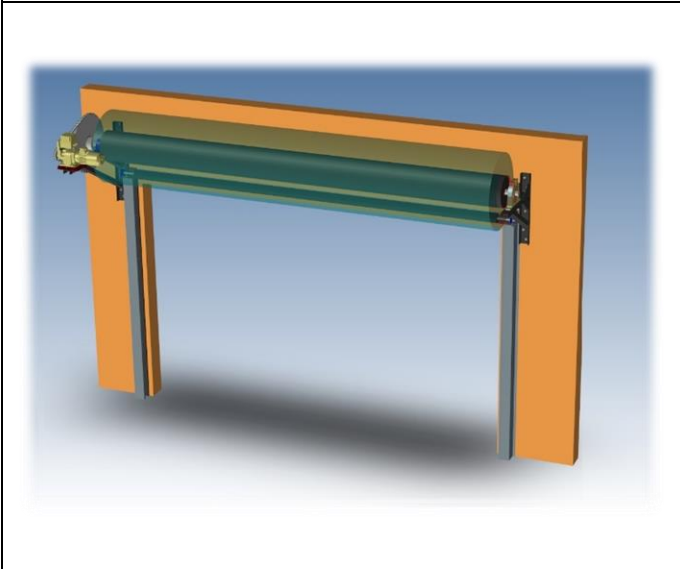

Attach the transmission to the motor and shaft

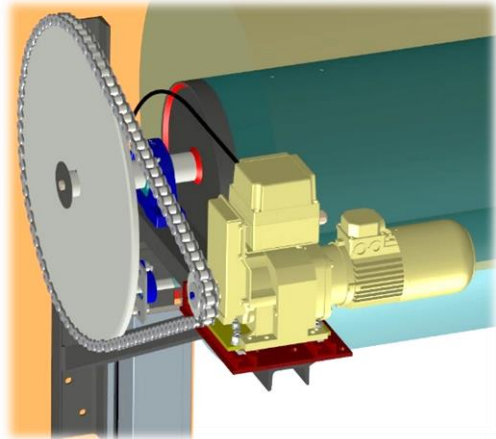

The bracket's type may vary depending on the type of motor chosen.

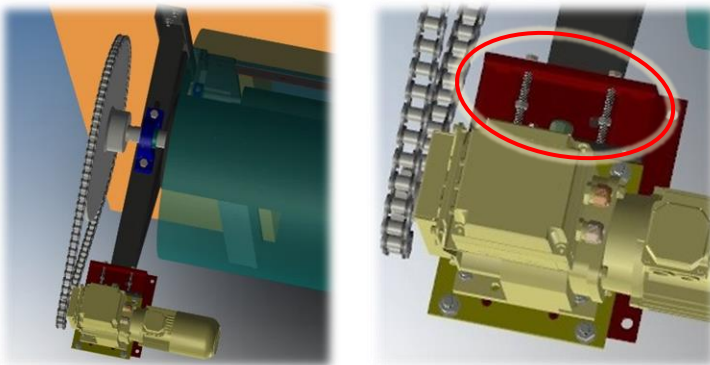

**Adjust the chain by acting on the chain tensioner screws.**



Bolt the motor to the respective adapter plate, slide it into the appropriate rails on the shelf. Insert the sprockets inside the relative axes. Place the chain and align the sprockets, then tight the respective grub screw to block them. Relocate the retaining washer on the axis.

**MOTOR NOTE**

Each motor is equipped with a key selector with manually adjustable limit switches for controlled descent (refer to the dedicated installation manual). A **continuous 24Vdc** fire alarm signal connected to the release solenoid allow the activation of the descent per gravity in controlled speed. *The signal must be continuous*, in case of interruption the solenoid will unlock the gravity descent. 24Vdc LED acoustic alarm as standard (*provide a dedicated line for activating the visual acoustic alarm*).

**Series JM: ATTENTION! SEE ALERT**

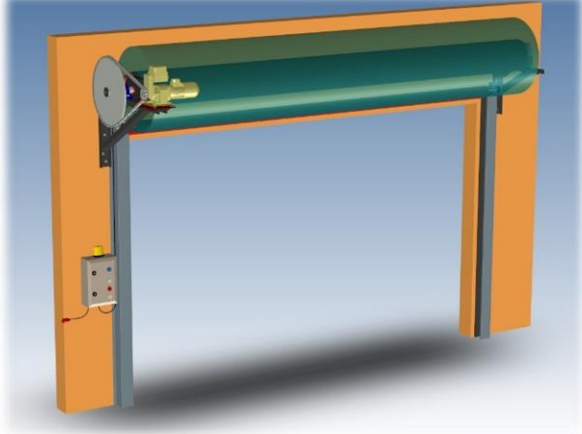

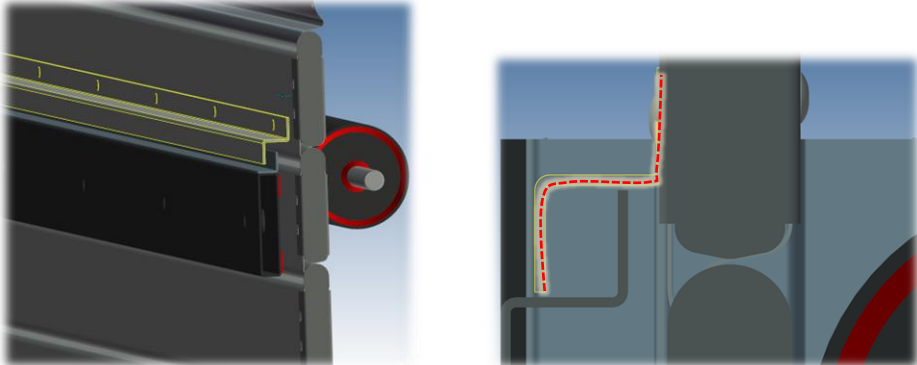
<p><b>MOTOR NOTE</b></p>	<p><b>Serie F: ATTENTION! SEE ALERT</b></p>
	<p>The type of control unit may vary depending on the motor chosen</p> 
<p>Step.08: Unroll the shutter inside the guides</p>	
	<p>Cut the containment straps and by acting on the control unit slowly unroll the shutter inside the guides. Adjust the push shaft maintaining the slats in vertical position. From the initial set up, the operating controls at point 10 pag.13 must be done at least every 6 months.</p>
<p>Step 9: Mounting Profile "Z" lock</p>	
 <p>Verify the correct fixing position of the profile, which, with the shutter completely closed, must be above the horizontal profile fixed to the lintel. Once this position has been marked on the element, the shutter must be rolled up so that it is accessible, drill 5mm holes (not through) and fix the Z profile with 4.8x8mm steel rivets.</p>	



**IMPORTANT**

All the spaces between the frame of the EW fire shutter (guides, transverse profile) and the masonry must be sealed with suitable foam ("Promafoam-C" type) not included in the supply.

**7. ELECTRICAL CONNECTIONS**

Refer to the instructions contained in the motor and control unit manuals.

**8. LIMIT SWITCHES'S ADJUSTMENT**

Refer to the instructions contained in the motor and control unit manuals.

**9. USE**

Before using the Fire Shutter, carry out the checks and operations listed below.

The Fire Shutter is equipped with all active and passive safety devices, to better safeguard the safety of the user and his parts. The efficiency over time of its performance and safety is subject to proper use and maintenance. For operating modes: refer to the instructions in the control panel manual.

**10. CONTROLS**

At the time of first start-up and *at least once every six months or 360 cycles*, the following checks must be carried out:

- Tightening of fastening systems (brackets, guides, crossbar);
- Tightening of fasteners (parachutes, bearings);
- Integrity of welds (brackets, shafts);
- Integrity of sliding guides and lintel;
- Integrity of the elements (verification of the tightening of the torx screws);
- Integrity of heat-expanding gaskets (bottom element, guides, beam plate) and sealing;
- Tensioning of the transmission chain, tightening sprocket grub screw and engine fixing bolts;
- Verification of the sliding of the elements in the guides;
- Verification of the efficiency of safety and control devices;
- Verification of the correct activation of the emergency lock;
- Check that the elements does not have uncontrolled movements during emergency closure;
- Noise control;
- Control of manual actuation forces (in the case of a motor equipped with an emergency manoeuvre);

**11. CLEANING AND LUBRICATION**

At the time of the first start-up and at least once every six months it is necessary to proceed with the cleaning of the side guides, shutter's slats and the lubrication of Transmission chain and Bearings eliminating by special means the excesses of dust or solid materials.

**WARNING**

**Do not use** solvents or other concentrated chemical compounds that could damage galvanized and painted finishes. **Do not use** high-pressure washers and do not convey water or steam jets to the electrical parts. Report to the MANUFACTURER particular and anomalous environmental situations, which may favor the accumulation of powdery or encrusting materials.

## 12. MAINTENANCE

For the perfect efficiency of the Fire Shutter, for the maintenance over time of the performance declared in the DOP and CE, plate and in accordance with the provisions of the mandatory safety regulations in the workplace, it is MANDATORY to carry out periodic and accurate maintenance by specialized personnel recognized by the MANUFACTURER, under penalty of forfeiture of the warranty.



### ATTENTION



Carry out maintenance with the shutter in **closed position**, making sure, in case of release of the electric brake, that the surface of the shutter does not have uncontrolled movements. Always, once the shutter is closed, turn off the power supply before any intervention.

**Check regularly that the chain is always in tension by acting, if necessary, on the chain tensioners (see page 11, step.07).**

The checks must be carried out at the timing indicated below or at least every 6 months.

CONTROL	FREQUENCY
Verification of the tension of the transmission chain.	2 MONTHS
Tightening of fastening systems (shelves, guides, beam plate);	6 MONTHS
Tightening of fasteners (safety brake, bearings);	6 MONTHS
Integrity of welds (shelves, shafts);	6 MONTHS
Integrity of the sliding guides and the beam plate in the lintel;	6 MONTHS
Integrity of the bottom element and slats;	6 MONTHS
Integrity of heat-expanding gaskets (guides, beam plates) and sealing;	6 MONTHS
Tightening sprocket grub screw and motor fixing bolts;	6 MONTHS
Sliding and alignment of the slats in the guides;	6 MONTHS
Integrity and efficiency of the control unit with UPS ( <i>if present</i> ) and of the safety devices ( <i>if any</i> ): flashing light; audible warning device;	6 MONTHS
Emergency closure drive cycle.	6 MONTHS
Noise of the motor;	6 MONTHS





## ATTENTION MOTOR SERIES F



### UPS BATTERIES MUST BE REPLACED EVERY TWO YEARS

In case of any anomaly, do not make careless maneuvers. Always request the intervention of a Specialized Technician. Irregular or unplanned maneuvers may cause damage to property or people THE MANUFACTURER will not assume any responsibility for damages or disturbances resulting from lack of periodic maintenance or negligence of the user

### NOTE

The *elements* (slats) are, particularly subject to wear during the operation of the Fire Shutter, and must always be kept in an excellent state of cleanliness and lubrication. In the event that the environmental conditions are particular, for example there is high humidity or concentration of dust in the air, high temperature ranges and / or conditions favorable to the increase of corrosive processes, it is advisable to increase the frequency of checks as well as lubrication interventions.

### 13. SPARE PARTS

The spare parts must be original, under penalty of forfeiture of any form of warranty.

To order them, it is sufficient to communicate to the MANUFACTURER the serial number shown on the CE plate, identifying with a photo the requested component.

### 14. TROUBLESHOOTING

The major problems that may occur on the Fire Shutter are summarized in the following table. If there are any unreported incidents, contact the MANUFACTURER.

Inconvenience	Probable cause	Solution
The shutter gets stuck during the ascent or descent	The shutter's slats are not perfectly aligned	Check the alignment of the shutter and the integrity of the lateral stops; Check the integrity of the guides and their gaskets;
The shutter does not work electrically	Lack of power supply	Wait for the power to be restored by the supply company
	Interruption of the fuse on the control panel	Replace the fuse with another of equal capacity
	Unsuitable power supply line	Check with the multimeter the voltage values 230/400 V with tolerance +/-10%
During an intensive operating cycle the shutter stops	Intervention of the thermal protections of the motor	Wait about ten minutes for the electrical parts of the motor to cool down, then try the maneuver again

The shutter starts but slows down and stops during the manoeuvre	Loss of insulation of the winding of the electric motor	Contact the Maintenance Company
Excessive noise	Lack of cleanliness and/or lubrication. Damaged lateral guide	Contact the Maintenance Company Verify the integrity of guides
Damage to elements of the shutter	Accidental events	Do not operate the shutter Contact the Maintenance Company
The shutter freezes during operation and does not start again	Intervention of the parachute device	Contact the Maintenance Company
	Intervention of the auxiliary safety limit box	Contact the Maintenance Company

## 15. GUARANTEE

According to laws in force from the date of supply. According to this warranty, the MANUFACTURER undertakes to repair or replace free of charge, as soon as possible, those parts that prove to be defective in materials or construction. Excluded from the warranty are those parts subject to wear in normal operation and failures due to force majeure, lack of maintenance, overloads, fraud, inexperience or negligence of the user. The MANUFACTURER guarantees the continuation of the services declared in DOP provided that the checks and maintenance required by a specialized and authorized company are carried out.

## 16. RISK ANALYSIS

Below is the risk analysis carried out on the Fire Rolling Shutter.

The shutter is equipped with all the necessary safety measures to eliminate, as far as reasonably possible, any risk. The risks and related remedies are listed in the safety requirements of *UNI EN 13241: 2016* and indicated in the following table:

RISK	SOLUTION
Fall protection of vertical sliding doors	Safety brake device was installed on the motorized axle. All structural elements are sized according to UNI EN 12604.
Cutting, blanking	Gasket mounted on the guides; Control with dead man maneuver.
Crushing, Collision	Control with dead man maneuver.

Conveying, Hooking	Blind coat and lack of protrusions $\geq 40$ mm;
Lifting	Control with dead man manoeuvre; Blind coat and lack of protrusions $\geq 40$ mm;
Loss of stability	Rigid brackets of guides and shelves; Tightening of bolts and fixing dowels; Verification of welds.
Emission of harmful substances	The shutter is built with materials that do not release harmful or dangerous substances to health.
Unexpected movements due to wind	The shutter is designed to withstand wind overloads declared in DOP.
Resistance to wind load	The shutter is designed to withstand wind overloads declared in DOP.
Installation and use	The shutter is equipped with a manual "Use, Maintenance and Safety"
Motorization units	Differential and magnetothermic protection on the supply line; Thermal protection in the engine; Safety devices with redundant control (where necessary).
Manual operation in case of emergency	Chain emergency maneuver (if included in the supply)
Extra stroke of the shutter	Auxiliary Safety limit box.

Residual risks are indicated on the shutter by applying the following signal

### RESIDUAL RISKS



RISK	SOLUTION
Electrocution	Do not intervene on the electrical parts without first cut of the power from the motor. Report the fault and wait for the intervention of specialized personnel.

## LOG BOOK OF ORDINARY AND EXTRAORDINARY MAINTENANCE

Pag.01

Date	Maintainer	Intervention type:	<input type="checkbox"/> Ordinary <input type="checkbox"/> Extraordinary
Description of the intervention carried out			
Replaced material			
Notes			
Signature of the Maintainer		Customer's signature	

Date	Maintainer	Intervention type:	<input type="checkbox"/> Ordinary <input type="checkbox"/> Extraordinary
Description of the intervention			
Replaced material			
Notes			
Signature of the Maintainer		Customer's signature	

**LOG BOOK OF ORDINARY AND EXTRAORDINARY MAINTENANCE****Pag.02**

Date	Maintainer	Intervention type:	<input type="checkbox"/> Ordinary <input type="checkbox"/> Extraordinary
Description of the intervention			
Replaced material			
Notes			
Signature of the Maintainer		Customer's signature	

Date	Maintainer	Intervention type:	<input type="checkbox"/> Ordinary <input type="checkbox"/> Extraordinary
Description of the intervention			
Replaced material			
Notes			
Signature of the Maintainer		Customer's signature	

**BLACKFIRE® is a trademark of CONEGLIANO GROUP SRL**

**LOG BOOK OF ORDINARY AND EXTRAORDINARY MAINTENANCE****Pag.03**

Date	Maintainer	Intervention type:	<input type="checkbox"/> Ordinary <input type="checkbox"/> Extraordinary
Description of the intervention			
Replaced material			
Notes			
Signature of the Maintainer		Customer's signature	

Date	Maintainer	Intervention type:	<input type="checkbox"/> Ordinary <input type="checkbox"/> Extraordinary
Description of the intervention			
Replaced material			
Notes			
Signature of the Maintainer		Customer's signature	

**BLACKFIRE® is a trademark of CONEGLIANO GROUP SRL**



## LOG BOOK OF ORDINARY AND EXTRAORDINARY MAINTENANCE

Pag.04

Date	Maintainer	Intervention type:	<input type="checkbox"/> Ordinary <input type="checkbox"/> Extraordinary
Description of the intervention			
Replaced material			
Notes			
Signature of the Maintainer		Customer's signature	

Date	Maintainer	Intervention type:	<input type="checkbox"/> Ordinary <input type="checkbox"/> Extraordinary
Description of the intervention			
Replaced material			
Notes			
Signature of the Maintainer		Customer's signature	

BLACKFIRE® is a trademark of CONEGLIANO GROUP SRL

**LOG BOOK OF ORDINARY AND EXTRAORDINARY MAINTENANCE****Pag.05**

Date	Maintainer	Intervention type:	<input type="checkbox"/> Ordinary <input type="checkbox"/> Extraordinary
Description of the intervention			
Replaced material			
Notes			
Signature of the Maintainer		Customer's signature	

Date	Maintainer	Intervention type:	<input type="checkbox"/> Ordinary <input type="checkbox"/> Extraordinary
Description of the intervention			
Replaced material			
Notes			
Signature of the Maintainer		Customer's signature	

**BLACKFIRE® is a trademark of CONEGLIANO GROUP SRL**

**LOG BOOK OF ORDINARY AND EXTRAORDINARY MAINTENANCE****Pag.06**

Date	Maintainer	Intervention type:	<input type="checkbox"/> Ordinary <input type="checkbox"/> Extraordinary
Description of the intervention			
Replaced material			
Notes			
Signature of the Maintainer		Customer's signature	

Date	Maintainer	Intervention type:	<input type="checkbox"/> Ordinary <input type="checkbox"/> Extraordinary
Description of the intervention			
Replaced material			
Notes			
Signature of the Maintainer		Customer's signature	

**BLACKFIRE® is a trademark of CONEGLIANO GROUP SRL**

